

# 2-5CP

## Multi-stage centrifugal pumps

 Clean water

 Domestic use



### 2-4CP

Impeller: Noryl



### 2-5CP -I

Impeller: stainless steel AISI 304



### PERFORMANCE RANGE

- Flow rate up to **130 l/min** (7.8 m<sup>3</sup>/h)
- Head up to **67 m**

### APPLICATION LIMITS

- Manometric suction lift up to **7 m**
- Liquid temperature:
  - between **-10 °C** and **+40 °C** for 2-5CP
  - between **-10 °C** and **+60 °C** for 2-5CP-I
- Ambient temperature up to **+40 °C**
- Max. working pressure **6 bar**
- Continuous service **S1**

### CONSTRUCTION AND SAFETY STANDARDS

EN 60335-1  
IEC 60335-1  
CEI 61-150

EN 60034-1  
IEC 60034-1  
CEI 2-3



### CERTIFICATIONS

Company with management system certified DNV  
ISO 9001: QUALITY



### INSTALLATION AND USE

Suitable for use with clean water and with liquids that are not chemically aggressive towards the materials from which the pump is made. As a result of their quietness, these pumps are widely used in domestic applications such as the distribution of water in combination with small and medium sized pressure tanks, and for the irrigation of gardens and orchards, etc. Installation needs to be undertaken in well ventilated closed areas or anyway protected from bad weather.

### PATENTS - TRADE MARKS - MODELS

- Registered EU Design n. 002073635-0001

### OPTIONS AVAILABLE ON REQUEST

- Other voltages or 60 Hz frequency

### CHARACTERISTIC CURVES AND PERFORMANCE DATA

50 Hz n= 2900 min<sup>-1</sup> HS= 0 m

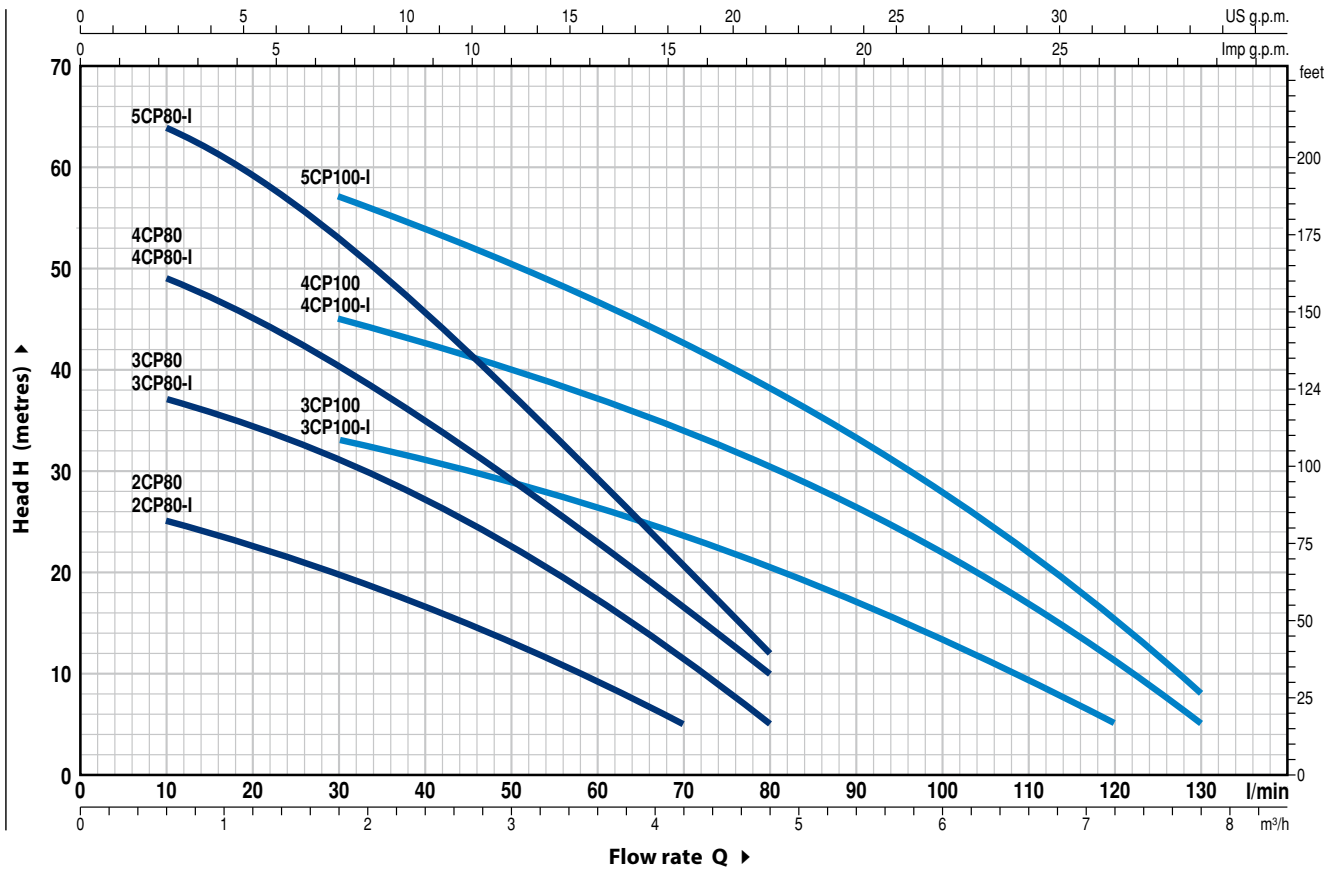

TIPO		POTENZA (P <sub>2</sub> )			Q	Flow rate (l/min)																		
Monofase	Trifase	kW	HP	▲		0	0.3	0.6	0.9	1.2	1.5	1.8	2.4	3.0	3.6	4.2	4.8	5.4	6.0	6.6	7.2	7.8		
2CPm 80	2CP 80	0.37	0.50	IE2	H metri	0	0.3	0.6	0.9	1.2	1.5	1.8	2.4	3.0	3.6	4.2	4.8	5.4	6.0	6.6	7.2	7.8		
2CPm 80-I	2CP 80-I					0	5	10	15	20	25	30	40	50	60	70	80	90	100	110	120	130		
3CPm 80	3CP 80	0.45	0.60			27	26	25	24	22.5	21	20	16.5	13	9	5								
3CPm 80-I	3CP 80-I					40	38	37	36	34.5	33	31	27	22.5	17	11	5							
4CPm 80	4CP 80	0.55	0.75			52	50	49	47	44.5	42	40	34	28.5	22.5	16	10							
4CPm 80-I	4CP 80-I					67	66	64	62	59	56	53	45.5	37.5	29.5	20.5	12							
5CPm 80-I	5CP 80-I	0.75	1			IE3																		
3CPm 100	3CP 100	0.55	0.75			IE2	38	37	36	35	34.5	33.5	33	31	28	26	23	20	17	13.5	10	5		
3CPm 100-I	3CP 100-I			50	50		49	48	47	46	45	42	39.5	37	34	30.5	26.5	22	17	11	5			
4CPm 100	4CP 100	0.75	1	IE3	63	62	61.5	60.5	59.5	58	57	53.5	50.5	46.5	42.5	38	33	28	22	15	8			
4CPm 100-I	4CP 100-I				63	62	61.5	60.5	59.5	58	57	53.5	50.5	46.5	42.5	38	33	28	22	15	8			
5CPm 100-I	5CP 100-I	1.1	1.5																					

Q = Flow rate H = Total manometric head HS = Suction height

Tolerance of characteristic curves in compliance with EN ISO 9906 Grade 3B.

▲ Three-phase motor efficiency class (IEC 60034-30-1)

# 2-5CP -I

## POS. COMPONENT

## CONSTRUCTION CHARACTERISTICS

1	<b>PUMP BODY</b>	Cast iron with an Epoxy Electro Coating treatment, with threaded ports in compliance with ISO 228/1				
2	<b>BODY BACKPLATE</b>	Stainless steel AISI 304				
3	<b>IMPELLERS</b>	Stainless steel AISI 304				
4	<b>DIFFUSERS</b>	Noryl complete with anti-wear ring				
5	<b>MOTOR SHAFT</b>	Stainless steel AISI 431				
6	<b>MECHANICAL SEAL</b>	<i>Seal</i>	<i>Shaft</i>	<i>Materials</i>		
		<i>Model</i>	<i>Diameter</i>	<i>Stationary ring</i>	<i>Rotational ring</i>	<i>Elastomer</i>
		AR-13	Ø 13 mm	Ceramic	Graphite	NBR
7	<b>BEARINGS</b>	<i>Pump</i>	<i>Model</i>			
		2CP 80-I	6202 ZZ - C3 / 6201 ZZ			
		3CP 80-I				
		4CP 80-I				
		3CP 100-I	6203 ZZ / 6203 ZZ			
		4CP 100-I				
5CP 80-I						
8	<b>CAPACITOR</b>	<i>Pump</i>	<i>Capacitance</i>			
		<i>Single-phase</i>	<i>(230 V or 240 V)</i>	<i>(110 V)</i>		
		2CPm 80-I	10 µF - 450 VL	25 µF - 250 VL		
		3CPm 80-I	12.5 µF - 450 VL	25 µF - 250 VL		
		4CPm 80-I	14 µF - 450 VL	25 µF - 250 VL		
		3CPm 100-I	20 µF - 450 VL	60 µF - 300 VL		
		4CPm 100-I		60 µF - 300 VL		
		5CPm 80-I		60 µF - 300 VL		
		5CPm 100-I	25 µF - 450 VL	60 µF - 300 VL		
9	<b>ELECTRIC MOTOR</b>	2-5CPm -I: single-phase 230 V - 50 Hz with thermal overload protector incorporated into the winding.				
		2-5CP -I: three-phase 230/400 V - 50 Hz.				
		<p>➔ <b>The three-phase pumps are fitted with high performance motors up to P2=0.55 kW in class IE2 and from P2=0.75 kW in class IE3 (IEC 60034-30-1)</b></p> <p>- Insulation: class F</p> <p>- Protection: IP X4</p>				

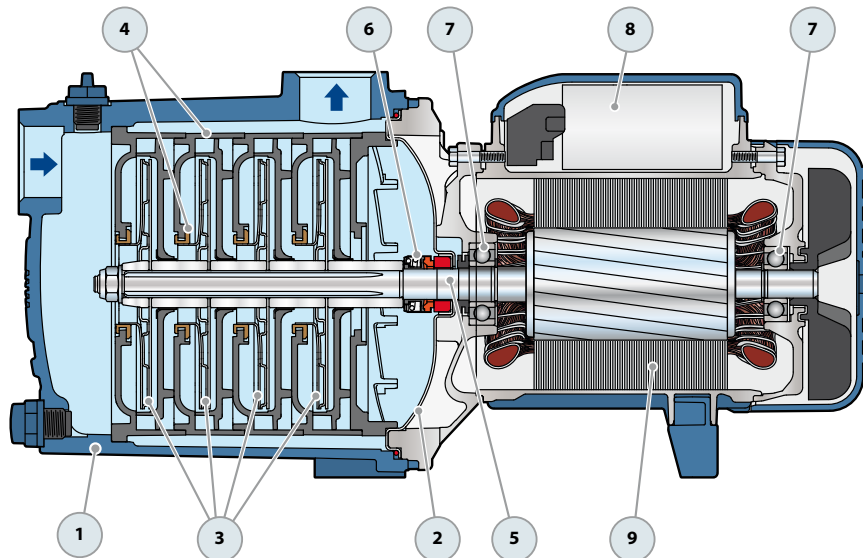

## DIMENSIONS AND WEIGHT

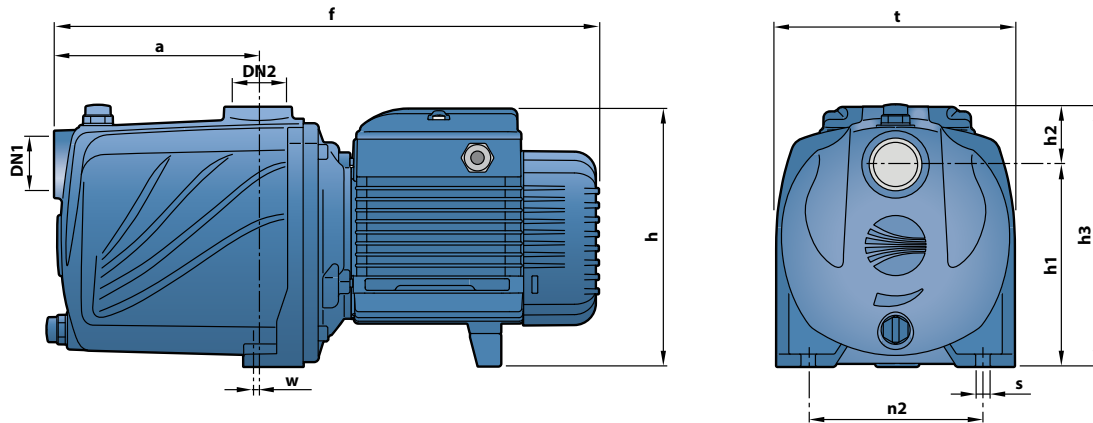

MODEL		PORTS		DIMENSIONS mm										kg	
Single-phase	Three-phase	DN1	DN2	a	f	h	h1	h2	h3	t	n2	w	s	1~	3~
2CPm 80-I	2CP 80-I	1"	1"	110	338	172	134	38	172	158	118	1	10	9.7	9.7
3CPm 80-I	3CP 80-I													10.7	10.7
4CPm 80-I	4CP 80-I			135	363	192 *								12.2	11.7
5CPm 80-I	5CP 80-I				382									15.1	15.1
3CPm 100-I	3CP 100-I			110	338	172								11.5	11.0
4CPm 100-I	4CP 100-I			135	382	192 *								14.9	14.9
5CPm 100-I	5CP 100-I													15.8	15.8

(\*) h=221 mm for single-phase versions at 110 V

## ABSORPTION

MODEL	VOLTAGE		
Single-phase	230 V	240 V	110 V
2CPm 80-I	2.4 A	2.3 A	4.4 A
3CPm 80-I	3.3 A	3.3 A	6.4 A
4CPm 80-I	4.0 A	3.8 A	7.8 A
5CPm 80-I	5.5 A	5.2 A	11.0 A
3CPm 100-I	3.9 A	3.7 A	7.8 A
4CPm 100-I	6.0 A	6.0 A	12.0 A
5CPm 100-I	6.6 A	6.4 A	13.2 A

MODEL	VOLTAGE					
Three-phase	230 V	400 V	690 V	240 V	415 V	720 V
2CP 80-I	1.7 A	1.0 A	0.6 A	1.7 A	1.0 A	0.6 A
3CP 80-I	2.5 A	1.5 A	0.9 A	2.4 A	1.4 A	0.8 A
4CP 80-I	3.4 A	2.0 A	1.2 A	3.3 A	1.9 A	1.1 A
5CP 80-I	4.3 A	2.5 A	1.4 A	4.1 A	2.4 A	1.3 A
3CP 100-I	3.4 A	2.0 A	1.2 A	3.3 A	1.9 A	1.1 A
4CP 100-I	4.0 A	2.3 A	1.3 A	3.8 A	2.2 A	1.3 A
5CP 100-I	4.3 A	2.5 A	1.4 A	4.2 A	2.4 A	1.4 A

## PALLETIZATION

MODEL		GROUPAGE	CONTAINER
Single-phase	Three-phase	n. pumps	n. pumps
2CPm 80-I	2CP 80-I	84	120
3CPm 80-I	3CP 80-I	84	120
4CPm 80-I	4CP 80-I	84	120
5CPm 80-I	5CP 80-I	72	108
3CPm 100-I	3CP 100-I	84	120
4CPm 100-I	4CP 100-I	72	108
5CPm 100-I	5CP 100-I	72	108